

Removing Particulate Matter from Diesel Engines has Never Been Easier!

Nett Technologies' VorTEQ™ 100 is an active diesel particulate filter (DPF) system that is designed to control particulate emissions from diesel engines in off-road applications. The VorTEQ™ 100 is an active system that is not dependent on exhaust gas temperature and is a practical diesel particulate control solution for diesel engines between 65hp to 300hp*. The VorTEQ™ 100 is an on-board regeneration system that requires no external power and is suitable for retrofitting a wide range of engines which are not factory fitted with a diesel particulate filter.

Nett Technologies designed the VorTEQ™ 100 active DPF system to effectively control diesel particulate matter emissions from diesel engines in construction machinery, such as; backhoes, forklifts, excavators, loaders, etc. Using its on-board display unit, the flexible VorTEQ™ 100 active DPF system performs regeneration during machine rest periods.

Using the VorTEQ™ 100 active DPF system, regeneration is possible even when the exhaust gas temperature is low (80 - 200°C). The system utilizes a wall-flow monolith substrate to capture the soot produced by diesel engines. The filter is regenerated using a diesel fuel burner, which periodically increases the filter temperature to a level necessary to oxidize the collected particulates. The VorTEQ™ 100 active DPF system typically provides 95%+ reduction in diesel particulate matter emissions and total elimination of black smoke.



VorTEQ™ 100 Active Diesel Particulate Filter

scan and learn



Sold and supported globally, Nett Technologies Inc., develops and manufactures proprietary catalytic solutions that use the latest in diesel oxidation catalyst (DOC), diesel particulate filter (DPF), selective catalytic reduction (SCR), engine electronics, stationary engine silencer, exhaust system and exhaust gas dilution technologies. Our reliable and real-world emission solutions will extend the usable life of existing equipment while allowing you to avoid costly future replacements. We manufacture emission control solutions that are California Air Resources Board (ARB) and the U.S. Environmental Protection Agency (EPA) verified. As the emission control authority, we are here to help you navigate through the hassles and complexities of emission control compliance.

NETT
TECHNOLOGIES INC.
...the emission control authority.

www.nettinc.com

PRODUCT SCHEMATICS

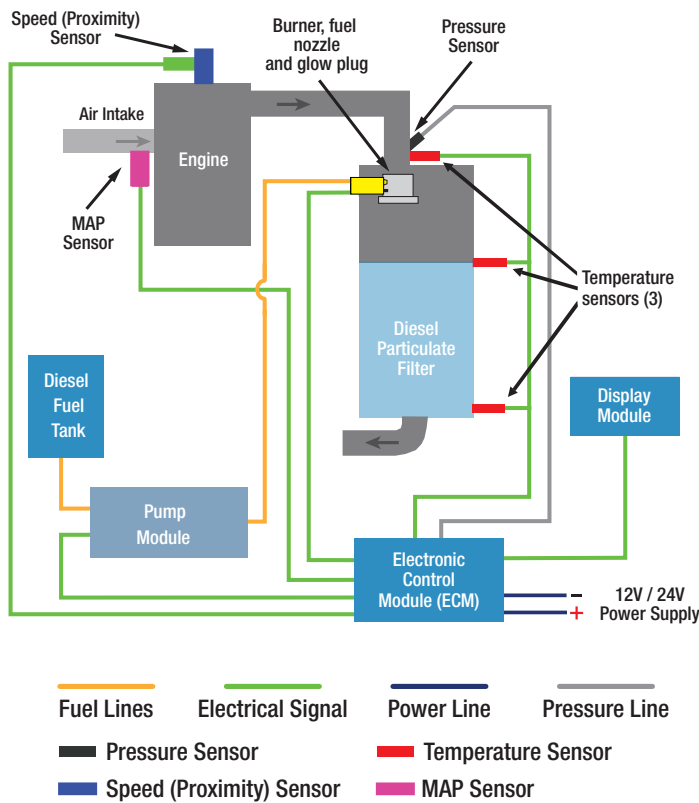

VorTEQ™ 100 PRODUCT FEATURES

- An active DPF system designed to control particulate matter emissions from diesel engines using a burner for periodic regenerations.
- Not dependent on variations in exhaust gas temperature - ideal for cold engine applications.
- California Air Resources Board Verified Technology.
- Engineered to work on engines between 65hp to 300hp* with a displacement no greater than 11.0L.
- Functional on certified engines with a PM emission level between 0.01g/bhp-hr and 0.2 g/bhp-hr.
- Sulphur level tolerable, also compatible with ultra low sulphur diesel (ULSD) and B20 biodiesel blend (20% biodiesel by volume).
- On-board display with real-time analytics. Real time display of DPF status, back pressure, temperatures, regeneration schedule and vital performance statistics.
- Reliable and economical with a long filter life.
- Engineered to install into tight engine compartment.
- No external power required to operate.
- Alerts operator when regeneration is required (audible and visual alarms).

SYSTEM EFFICIENCIES

The particulate matter filtration efficiency of the system typically exceeds 95%. The filtration efficiency of the elemental carbon fraction of diesel particulates (soot) is 95-99%.



Typical VorTEQ™ 100 Emissions Reduction Performance

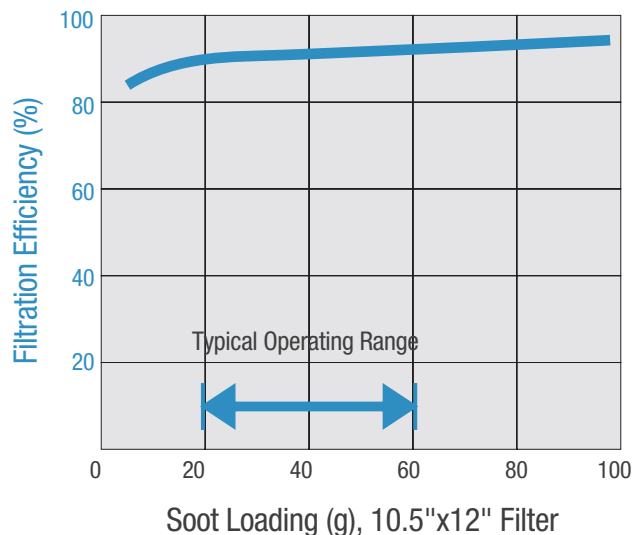

* System HP range is being extended to 300Hp through ARB



...the emission control authority.

Contact Nett Technologies Inc. today at:

Phone: (905) 672-5453 Toll-Free: 1(800) 361-6388
or visit us online at www.nettinc.com

Distributed by:

