

Marine diesel emission control, the easy way!

Diesel engines are an excellent power source, with the exception of their emissions. Particulate Matter (PM)/soot is an ongoing issue causing frustration, additional work for the crew, possibly mechanical difficulties, and loss of enjoyment in a pleasure boat environment.

The GreenTRAP™ 320 system is a passive PM control system. The diesel filters utilize cordierite wall-flow monoliths to trap the soot that is produced by the diesel engines.

The proprietary catalyst is coated onto the inside surface of the filter monolith which lowers the soot combustion temperature allowing the filter to self-clean (regenerate). All of the accumulated soot is then oxidized in the filter during regular operation of the diesel engine. In favorable operational conditions the system in addition to 95-99% PM reduction will reduce Carbon Monoxide (CO) and Hydrocarbon (HC) emissions greater than 90% and 95% respectively.

The GreenTRAP™ 320 PM control system is customized to fit your specific application, providing you full control over PM, rather than allowing PM to control you.

GreenTRAP™
320

passive diesel particulate filter

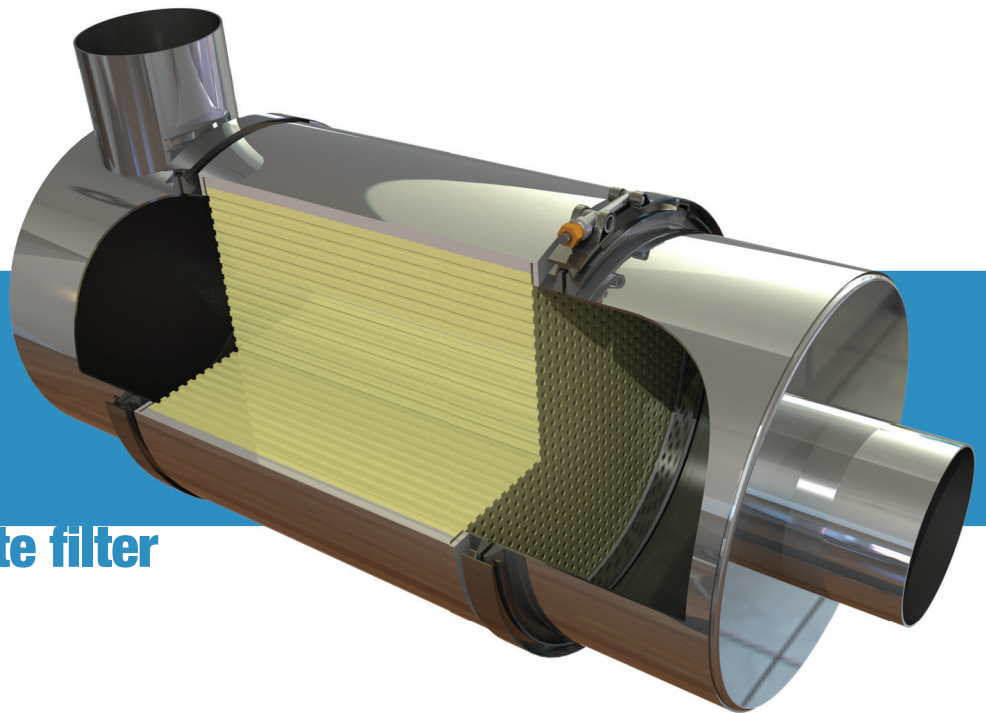

scan and learn



Sold and supported globally, Nett Technologies Inc., develops and manufactures proprietary catalytic solutions that use the latest in diesel oxidation catalyst (DOC), diesel particulate filter (DPF), selective catalytic reduction (SCR), engine electronics, stationary engine silencer, exhaust system and exhaust gas dilution technologies. Our reliable and real-world emission solutions will extend the useable life of existing equipment while allowing you to avoid costly future replacements. We manufacture emission control solutions that are California Air Resources Board (ARB) and the U.S. Environmental Protection Agency (EPA) verified. As the emission control authority, we are here to help you navigate through the hassles and complexities of emission control compliance.

NETT
TECHNOLOGIES INC.
...the emission control authority.

www.nettinc.com

GreenTRAP™ 320 PRODUCT OVERVIEW

How does the GreenTRAP™ 320 work?

Diesel filters utilize cordierite wall-flow monoliths to trap the soot produced by diesel engines. The cylindrical filter element consists of many parallel channels running in the axial direction, separated by thin porous walls. The channels are open at one end and plugged at the other, forcing the particle laden exhaust gases to flow through the walls. Gases are able to escape through the pores in the wall material, but particulates are too large to escape and are trapped in the filter.

A proprietary catalyst is coated onto the inside surface of the filter monolith. The catalyst lowers the soot combustion temperature allowing the filter to regenerate. The accumulated soot is oxidized in the filter during regular operation of the engine. Exhaust temperatures of 530-575°F for 25-30% of the operation time are necessary for proper filter regeneration, when ULSD (ultra-low sulfur diesel) fuel is used. This can be met on most heavy-duty diesel engine applications, as well as on some medium and light duty engines. Nett filters can be used with all fuels, with preferably no more than 500ppm sulfur content; however, higher exhaust temperatures will be required for regeneration.

Typical exhaust gas pressure drop on a properly regenerating filter is between 5 and 10 kPa (20-40"H₂O). Applications on new diesel engines with low engine-out particulate emissions or with higher exhaust temperatures regenerate better, accumulate less soot in the filter, and experience lower pressure drop. In favorable operational conditions, the system can reduce up to 95% of Carbon Monoxide (CO), 90% of Hydrocarbons (HC) and 90% of Particulate Matter (PM).

The monitoring system along with 2 temperature sensors and 1 differential pressure sensor are used to monitor the DPF backpressure and DPF inlet/outlet temperatures in real time.

GreenTRAP™ 320 System Schematic Drawing

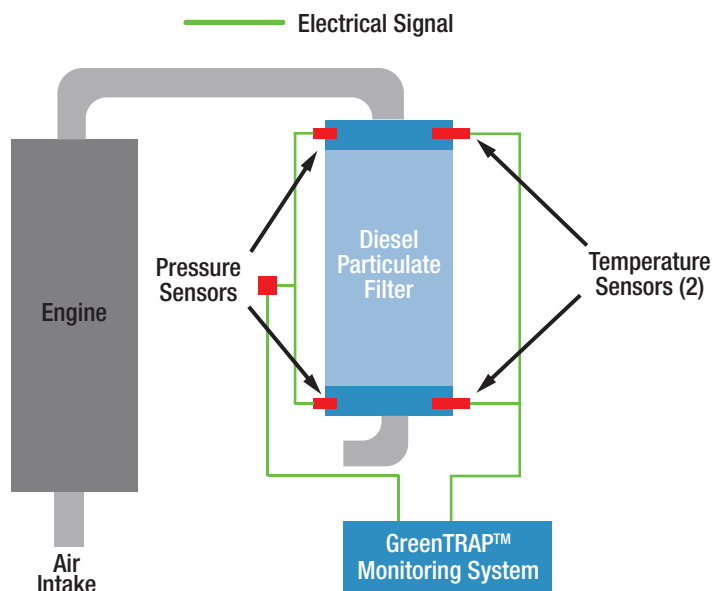

PRODUCT FEATURES

- Passive system
- Ideal for engines with an overall output of (50kw to 450kw)
- Internally and externally (optional) insulated
- Computerized controller with 3 customizable alarms and data logging capabilities
- System maintenance intervals of (2000 to 5000 hours)
- Colour display informing of system operational conditions and status

EMISSIONS REDUCTION PERFORMANCE

Typical GreenTRAP™ 320 Emissions Reduction Performance

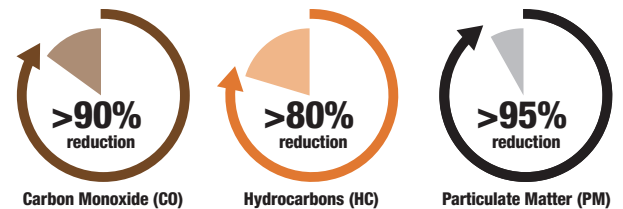

...the emission control authority.

Contact Nett Technologies Inc. today at:

Phone: (905) 672-5453 Toll-Free: 1(800) 361-6388
or visit us online at www.nettinc.com