



Nett Technologies Inc.

6154 Kestrel Road, Mississauga, Ontario
Canada L5T 1Z2

tel: 905.672.5453

fax: 905.672.5949

e-mail: sales@nettinc.com

web: www.nettinc.com

technical manual

BlueCAT 200™

Executive Order G-09-011

BlueCAT 300™

Executive Order G-09-012

BlueCAT 300™

Executive Order G-09-013

California Air Resources Board

Verified Retrofit Emissions Control System

For 1980 and Later

Uncontrolled Gaseous Fuelled LSI Engines

Product Description.....	3
Overview	3
Applications.....	3
Retrofit Requirements.....	4
System Labels	5
Principle of Operation	5
Installation Instructions	7
Step 1: Installing the 3-Way Catalytic Muffler/Converter - Important Note.....	7
Step 2: Install the BlueCAT Electronic Control Unit (ECU)	9
Step 3: Install the Oxygen Sensor	9
Step 4: Install the Solenoid Valve	9
Step 5: Install the Vacuum Line	9
Step 6: Complete the Electrical Connections	12
Calibration	13
BlueCAT Indicator Lights	13
Fuel System Set up Procedures	14
Maintenance & Troubleshooting	15
Detailed Troubleshooting Procedure	16
Item List & Part Numbers	17
Manufacturer Warranty	18
Installation Warranty	19

Product Description

Overview

The BlueCAT 200™ and BlueCAT 300™ are Retrofit Emissions Control Systems which have been verified by the California Air Resources Board for installation on uncontrolled gaseous fueled Large Spark Ignited (LSI) engines.

Kit Name	Emissions Verification Level
BlueCAT 200™	2.0 Grams per Kilowatt/Hour 1.5 Grams per Brake HP/Hr.
BlueCAT 300™ (Engines Below 3.0L)	1.3 Grams per Kilowatt/Hour 1.0 Grams per Brake HP/Hr.
BlueCAT 300™ (Engines Above 3.0L)	2.7 Grams per Kilowatt/Hour 2.0 Grams per Brake HP/Hr.

The BlueCAT 200™ consists of a digital air-to-fuel (A/F) ratio controller for gaseous fuelled, carbureted large spark ignited engines, and a 3-Way catalytic converter/muffler. By precisely maintaining the optimal A/F ratio (also known as the stoichiometric A/F ratio) under all engine operating conditions, the unit maximizes emission reductions in the 3-way catalyst. The controller also reduces fuel consumption and increases engine life.

The BlueCAT 300™ also consists of a digital air-to-fuel (A/F) ratio controller for gaseous fuelled, carbureted large spark ignited engines, and a 3-Way catalytic converter/muffler. By precisely maintaining the optimal A/F ratio (also known as the Stoichiometric A/F ratio) under all engine operating conditions, the unit maximizes emission reductions in the 3-way catalyst. The controller also reduces fuel consumption and increases engine life.

Both controllers incorporate an on board diagnostic system, which allows for constant monitoring of the operation and simplifies set-up. The combination of lights built directly into the unit provides an indication of controller operation without the need for additional monitoring tools. The diagnostic functions include a power and failure light, a warm up and O₂ sensor light, and a set of lights to monitor the percentage of A/F ratio modulation. Both units also include a dashboard-mountable warning light to alert the operator in case of system failure and to prevent the release of excessive emissions.

The BlueCAT 200™ and BlueCAT 300™ both use the same basic technology to operate, and are externally identical except for the identification plates. Internally the BlueCAT 300™ uses a more advanced catalyst and slightly different tuning of the control circuitry for improved emissions reductions.

Applications

The BlueCAT system can control A/F mixtures on carbureted engines fueled by liquefied petroleum gas (LPG, “propane”, “propane-butane”) and by compressed natural gas (CNG).

It is primarily designed to work with air-valve type gaseous carburetor systems, including IMPCO, Nolf's, and equivalent products. The controller is also compatible with most venturi-type gaseous carburetors, such as Aisan, Beam, or Garretson.

The controller is not intended, nor legal for installation on gasoline fueled engines, or for use on engines with electronic fuel injection systems. To install either BlueCAT system on a gasoline fueled engine it is first necessary to convert it to a carbureted LPG/CNG fuel system, after which installation can occur.

Retrofit Requirements

NOTE: Only Overhead Valve Engines can be retrofitted.

To meet government regulatory requirements for retrofitting a 1980 or later LSI engine the following steps are necessary. Failure to follow these steps will void the BlueCAT warranty, and make the engine non-compliant with the regulations.

While the steps may be done in a different order, any failure will invalidate the engine as a retrofit candidate until the defect is corrected, after which the steps must be carried out in full again.

All work must be carried out by a technician who holds the appropriate license(s) required to legally repair/maintain the engine/machine in question, for the jurisdiction where the work is performed.

1. Check the Cylinder Compression for all cylinders. If all cylinders are at 90% or better of the manufacturer's specifications for compression go to step 2, otherwise rebuild the engine.
2. Confirm that the engine has an LPG or VPG Fuel System installed. If there is not one installed you must either install one or stop the retrofit installation.
3. Inspect for signs of excessive engine oil consumption and repair as necessary to engine manufacturer's specifications.
4. Use a Pressure Gauge with a 0-15 PSI range to check the output pressure on the Fuel Regulator and adjust the regulator to the manufacturer's specification. If the regulator cannot be adjusted to the manufacturer's specifications replace it with a new unit and repeat this test (Note: It may be possible to install a repair kit instead.)
5. Use the appropriate equipment to check the Engine Timing against the manufacturer's specifications, and adjust if required.
6. Inspect all Spark Plugs for wear and replace if necessary. Check Spark Plug gap against the manufacturer's specifications, and adjust if necessary.
7. Inspect the Ignition System, including but not limited to the Distributor Cap, Rotor, Wires, Breaker Points, Condenser, Coil, etc. Replace any and all parts that are not functioning according to the manufacturer's specifications.
8. Inspect Carburetor/Mixer assembly for wear. Replace any worn parts (note that if there is even the slightest play in the throttle shaft, either it or the throttle body must be replaced). Check the Air Valve – if a Feedback Air Valve is not installed, install one and discard the original Air Valve.
9. Install a new Service Kit in the Carburetor/Mixer, and make the appropriate adjustments to get the engine running properly, then adjust the mixture so that the engine is now running slightly rich.
10. Inspect the Cooling System, clean dust/dirt out of the radiator fins if necessary. Pressure test the system. Insure that there are no leaks of coolant into the engine lubricating oil.
11. Inspect the Fuel System Hoses. If the hoses are Type 1 or 2, replace with Type 3 hoses.

12. Change Engine Oil and Filter.
13. Inspect Fuel System Filter, and replace if necessary.
14. Replace the Air Filter.

Again, any failure must be corrected, or the warranty will be voided, and the retrofit will not legally change the emissions value of the engine/machine.

System Labels

Two labels are required on each installation. One label will be affixed to the muffler and the other will be included in the controller kit. This second durable label with peel-and-stick backing is to be installed on the engine in clear view after the surface is cleaned and dry. The surface temperature must be at least 50°F (10°C) for proper label adhesion. These labels will be preprinted with all necessary details including: system name, manufactured date, emission control group name, model and serial numbers.

System	Label Affixed to Muffler Dimensions: 3.00 x 1.875" (76 x 48mm)	Label to be Affixed to Engine Dimensions: 3.25 x 1.75" (83 x 44mm)
BlueCAT 200™	<p>Nett Emission Control System</p> <p>System: BlueCAT 200 Manufactured: XX-XX</p> <p>Emission Control Group Name: CA/2006/NET/LL3a/NH1.5/OFF/SYS01</p> <p>Model: XXXXX-BLUECAT200 Serial Number: BC2-XXXX</p> <p>Nett Technologies Inc. Tel: 800-361-6388 2-6707 Goreway Drive or 905-672-5453 Mississauga, ON L4V 1P7 Made in Canada</p>	<p>Nett Emission Control System</p> <p>System: BlueCAT 200 Emissions (Metric): 2.0 g/kW-hr Emissions (Imperial): 1.5 g/bhp-hr</p> <p>Emission Control Group Name: CA/2006/NET/LL3a/NH1.5/OFF/SYS01 Manufactured: XX-XX</p> <p>Model: XXXXX-BLUECAT200 Serial Number: BC2-XXXX</p> <p>NETT Nett Technologies Inc. Tel: 800-361-6388 2-6707 Goreway Drive or 905-672-5453 Mississauga, ON L4V 1P7 Made in Canada</p>
BlueCAT 300™ Engines Below 3.0L	<p>Nett Emission Control System</p> <p>System: BlueCAT 300 Emissions (Metric): 1.3 g/kW-hr Emissions (Imperial): 1.0 g/bhp-hr</p> <p>Emission Control Group Name: CA/2007/NET/LL3a/NH1.0/OFF/SYS01 Manufactured: 10-XX</p> <p>Model: XXXXX-BLUECAT300 Serial Number: BC3-XXXXX</p> <p>NETT Nett Technologies Inc. tel: 800-361-6388 6154 Kestrel Road or: 905-672-5453 TECHNOLOGIES INC. Mississauga, ON L5T 1Z2 Made in Canada</p>	<p>Nett Emission Control System</p> <p>System: BlueCAT 300 Emissions (Metric): 2.7 g/kW-hr Emissions (Imperial): 2.0 g/bhp-hr</p> <p>Emission Control Group Name: CA/2009/NET/LL3a/NH2.0/OFF/SYS01 Manufactured: 10-XX</p> <p>Model: XXXXX-BLUECAT300 Serial Number: BC3-XXXXX</p> <p>NETT Nett Technologies Inc. tel: 800-361-6388 6154 Kestrel Road or: 905-672-5453 TECHNOLOGIES INC. Mississauga, ON L5T 1Z2 Made in Canada</p>
BlueCAT 300™ Engines Above 3.0L	<p>Nett Emission Control System</p> <p>System: BlueCAT 300 Emissions (Metric): 2.7 g/kW-hr Emissions (Imperial): 2.0 g/bhp-hr</p> <p>Emission Control Group Name: CA/2009/NET/LL3a/NH2.0/OFF/SYS01 Manufactured: 10-XX</p> <p>Model: XXXXX-BLUECAT300 Serial Number: BC3-XXXXX</p> <p>NETT Nett Technologies Inc. tel: 800-361-6388 6154 Kestrel Road or: 905-672-5453 TECHNOLOGIES INC. Mississauga, ON L5T 1Z2 Made in Canada</p>	<p>Nett Emission Control System</p> <p>System: BlueCAT 300 Emissions (Metric): 2.7 g/kW-hr Emissions (Imperial): 2.0 g/bhp-hr</p> <p>Emission Control Group Name: CA/2009/NET/LL3a/NH2.0/OFF/SYS01 Manufactured: 10-XX</p> <p>Model: XXXXX-BLUECAT300 Serial Number: BC3-XXXXX</p> <p>NETT Nett Technologies Inc. tel: 800-361-6388 6154 Kestrel Road or: 905-672-5453 TECHNOLOGIES INC. Mississauga, ON L5T 1Z2 Made in Canada</p>

Principle of Operation

Remember that the BlueCAT 200™ and BlueCAT 300™ are externally identical other than the identification plates. Both are installed and setup in the same manner.

Figure 1 shows the main functional components of the BlueCAT systems, including the electronic control unit (ECU), oxygen sensor, and solenoid valve. The oxygen

(O₂) sensor, installed in the vehicle exhaust system upstream of the Nett® 3-way catalytic converter or catalytic muffler, continuously monitors the exhaust gas composition. Lean A/F mixtures produce exhaust gases of high oxygen concentration, while rich A/F mixtures produce exhaust gases with little or no oxygen. A feedback signal from the oxygen sensor is passed to the ECU, which controls the vehicle's fuel system to maintain the optimal, stoichiometric A/F ratio.

A/F mixture control is achieved by biasing the diaphragm in the fuel regulator using vacuum taken from an area above the throttle in the fuel mixer. This vacuum signal is passed to the fuel regulator through the solenoid valve. ECU-controlled modulation of this valve determines the amount of vacuum signal that can pass to the regulator. The more vacuum passed to the regulator, the more restricted the flow of fuel and, consequently, the leaner the A/F mixture.

Since the A/F mixture can only be made leaner (as opposed to richer) by the described control mechanism, it is required that the vehicle's fuel system be calibrated to a rich mixture during the set up of the controller. Once installed and set up, as outlined in the set up procedures, the BlueCAT controller leans the mixture, as may be required at different speed and load conditions, to maintain a stoichiometric A/F ratio.

Feedback air valves must be used with IMPCO carburetors for best control:

- Model 100 Carbs use IMPCO P/N: AV1-1447-2
- Model 200 Carbs use IMPCO P/N: AV1-1245-2

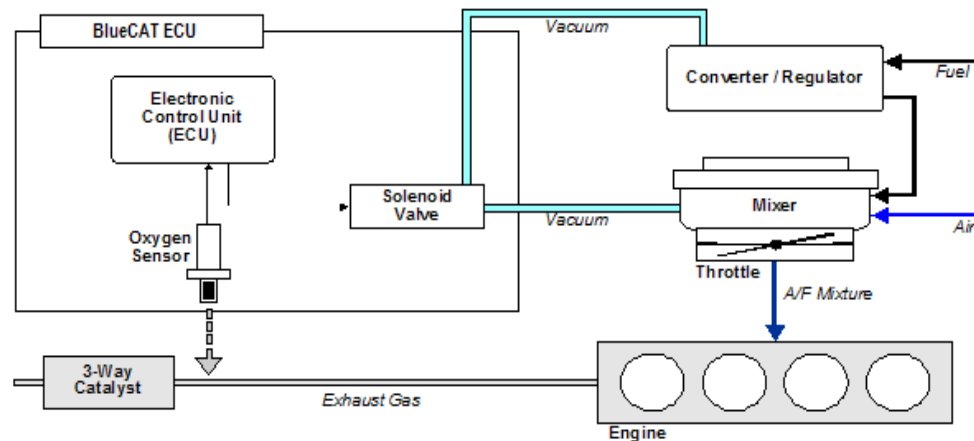

Figure 1: BlueCAT Control System Schematic

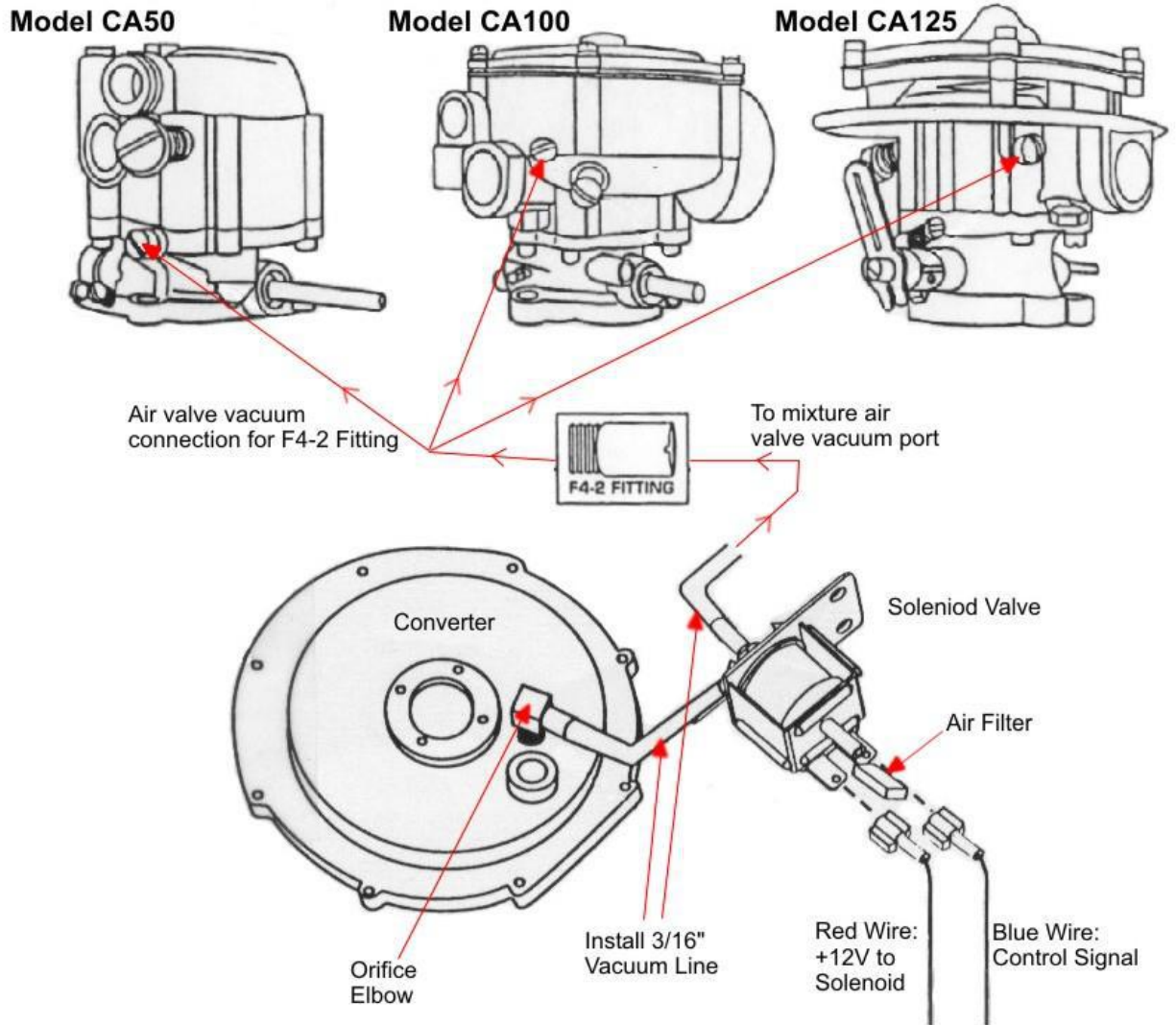

Figure 2: Impco Fuel System installation

Important: It is strongly recommended that the engine be serviced, and set to manufacturer's specifications prior to the installation of the BlueCAT system. In particular, the intake air and fuel filter elements must be inspected and replaced or cleaned if needed.

Step 1: Installing the 3-Way Catalytic Muffler/Converter - Important Note

It is important that there are no leaks in the exhaust system upstream of the muffler/converter. U-Bolt style clamps should not be used as they do not provide a reliable seal. Nett Technologies recommends the use of 1" wide band-style clamps.



The chart below lists sizes and part numbers for several manufacturers who make this type of clamp. The following list shall not be construed in any way as an explicit endorsement by Nett Technologies Inc.

technical manual

Pipe Size (OD)	Clamps Inc.	Clamps Inc.	Donaldson	Nelson	Nelson	Walker
1.50"		BCE 150				
1.63"		BCE 158				
1.75"	NBC 175	BCE 175				
1.88"		BCE 188				
2.00"	NBC 200	BCE 200	J000204	90869A	900016A	
2.13"		BCE 213				
2.25"	NBC 225	BCE 225	J000205	90870A	900017A	
2.50"	NBC 250	BCE 250	J000206	90871A	900018A	
2.75"	NBC 275	BCE 275	J000207	90872A	900019A	
3.00"	NBC 300	BCE 300	J000200	90873A	900003A	
3.25"		BCE 325				
3.50"	NBC 350	BCE 350	J000201	90874A	900004A	
3.88"		BCE 388				
4.00"	NBC 400	BCE 400	J000202	90875A	90885A	35227
4.25"		BCE 425				
4.50"		BCE 450	J000208	90876A		
5.00"	NBC 500	BCE 500	J000203	90877A	90887A	35228
6.00"	NBC 600	BCE 600	J000209	90878A	90888A	33316

- Clamps Inc <http://www.clampsinc.com>
- Donaldson <http://www.donaldson.com>
- Nelson <http://www.nelsondiv.com>
- Walker/Tenneco <http://www.tenneco-automotivehd.com/>

Step 2: Install the BlueCAT Electronic Control Unit (ECU)

The unit can be installed in the engine compartment, under the dashboard, or on the dashboard for operator monitoring. The location should permit the wiring harness to reach the oxygen sensor and the solenoid valve.

Caution: Exposure to high temperatures can damage the BlueCAT ECU. When mounted in the engine compartment, the unit should be installed in a reasonably cool location, preferably at the opposite side of the engine relative to the exhaust manifold and at least 30 cm (12") away from exhaust piping.

Step 3: Install the Oxygen Sensor

The oxygen sensor must be installed into a threaded M18 port in the exhaust pipe or at the inlet to the catalytic converter/muffler. All Nett® BlueCAT 3-way catalytic converter/mufflers come with an oxygen sensor port pre-installed in the inlet section of the muffler. Simply install the oxygen sensor in this port.

Caution: Exposure to high temperatures can damage the oxygen sensor or shorten its life. When mounted in the exhaust pipe, the unit should be placed at least 25 cm (10") away from the exhaust manifold.

Step 4: Install the Solenoid Valve

Secure the solenoid valve to the converter/regulator cover using one of the converter cover screws.

If the engine is to be operated in dusty environment, install the foam filter on the air port of the solenoid valve (it is the brass port of the solenoid located in the proximity to the electrical connections, as shown in Figure 2). Making sure that the port opening is not blocked, place a drop of adhesive on the brass port and place the foam filter over the port.

Step 5: Install the Vacuum Line

This step involves (1) the installation of the vacuum elbow into the fuel converter/regulator, (2) connecting the elbow with the solenoid valve, (3) installing the vacuum fitting in the mixer and (4) connecting the solenoid valve with the mixer vacuum. Solenoid valve ports are referenced in Figure 2 (on page 10).

(1) Locate the atmospheric vent on the converter; it will either be on the cover (IMPCO, Nolf's) or at the base of the converter (Aisan).

IMPCO, Nolf's - remove the vent screen; install the plastic vacuum elbow into the threaded port. Note that on some systems a balance line between the converter and the Mixer may exist which uses the atmospheric vent port. If it is installed, remove the fitting from the converter and install our fitting. Also check the section on mixers.

Aisan Standard System - tap the vent hole 1/8 N.P.T., install the plastic vacuum elbow

Aisan System with Resonator – Disconnect the vacuum hose from the resonator to the converter/regulator. Remove the press fit vacuum fitting from the converter. Tap the hole 1/8 NPT, and install the plastic vacuum elbow. Remove the vacuum line from the resonator to the air inlet tube. Plug the hole in the air inlet tube. Disconnect the resonator from the machine and discard.

If possible, position the orifice downward to allow moisture which may accumulate in the line to drain. Note: Do not over-tighten (to avoid breaking the plastic thread).

(2) Cut sufficient length of the flexible vacuum hose and connect the vacuum elbow with the plastic vacuum port on the side of the solenoid valve (see Figure 2 on page 10).

(3) Identify a vacuum port in the mixer and install the vacuum fitting.

Air Valve Mixers:

IMPCO, Nolff's: These mixers have a predrilled port to access the air valve vacuum. This port is located in the area between the throttle and the mixer air valve. It is usually plugged by a small, chromium-plated screw (Impco PN S1-69). Simply remove the screw and install the included brass vacuum fitting. Note that if a balance line is installed it may use this port, if so remove and discard. On some mixers the balance line will hook into the upper mixer body, if so remove and discard it, and plug the port, see items 21, 56, 59 & 60 below.

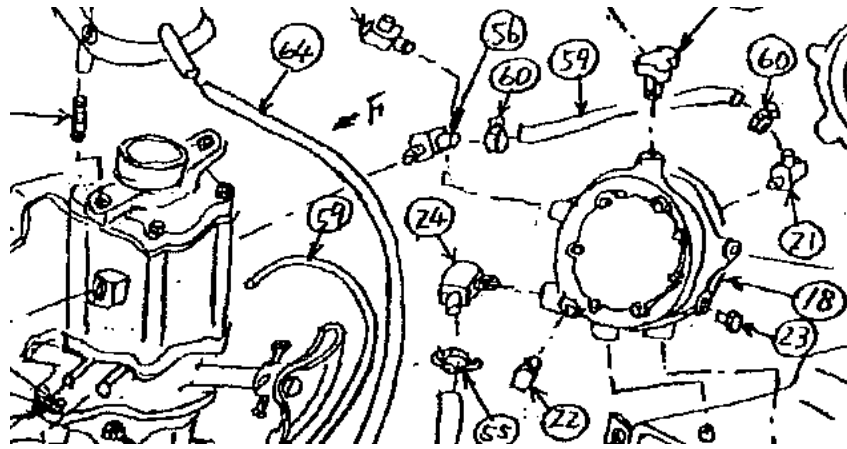

Figure 3: Impco Fuel System with Balance Line

Venturi mixers: Most venturi-type mixers (Aisan, Beam) have no predrilled vacuum ports. In such case, the mixer has to be drilled and tapped before the vacuum fitting can be installed. If possible, venturi vacuum should be used by drilling the mixer just underneath the venturi nozzle. Fig ?a Alternatively, the vacuum can be taken from the mixer throat at any place between the venturi and the throttle using a 7/32" drill bit. Tap the hole to 1/4" x 28 thread pitch and install the brass fitting supplied.

On Aisan mixers the location adjacent to the casting boss (right hand side) is preferred. On Aisan dual fuel systems drill the hole into the intake elbow of the power valve section to access the air valve vacuum.

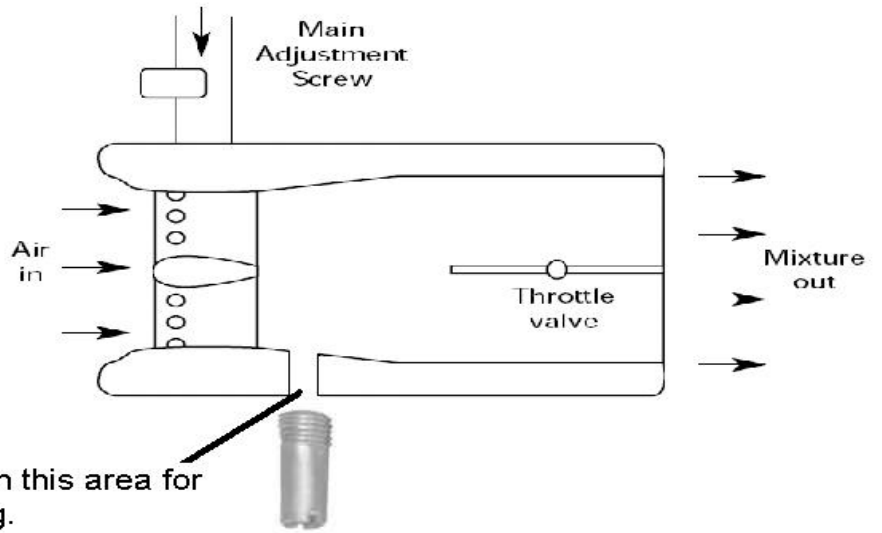

Fig 4a: Generic Fixed Venturi Vacuum Location



Figure 4b: Aisan Mixer – Location of vacuum port

Important: The source of vacuum must be from a point above the engine throttle. The controller works properly at vacuums between about 1 – 3 kPa (4 – 12" H₂O). Connecting the BlueCAT to engine manifold vacuum will result in unstable operation and may result in serious loss of vehicle's drivability.

Cut sufficient length of the flexible vacuum hose and connect the vacuum fitting in the mixer with the remaining plastic vacuum port of the solenoid valve (see Figure 2).

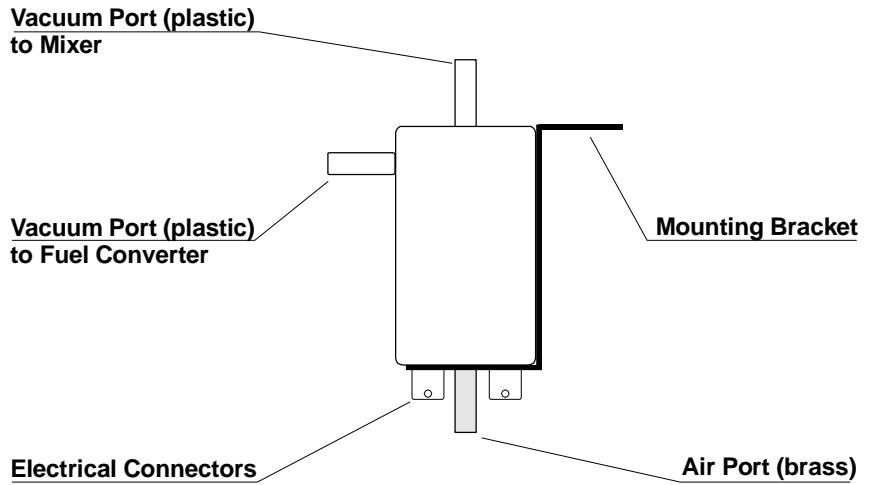

Figure 5. Solenoid Valve Ports

Step 6: Complete the Electrical Connections

Once installed, the unit must be wired into the forklift 12V electrical system following the diagram below.

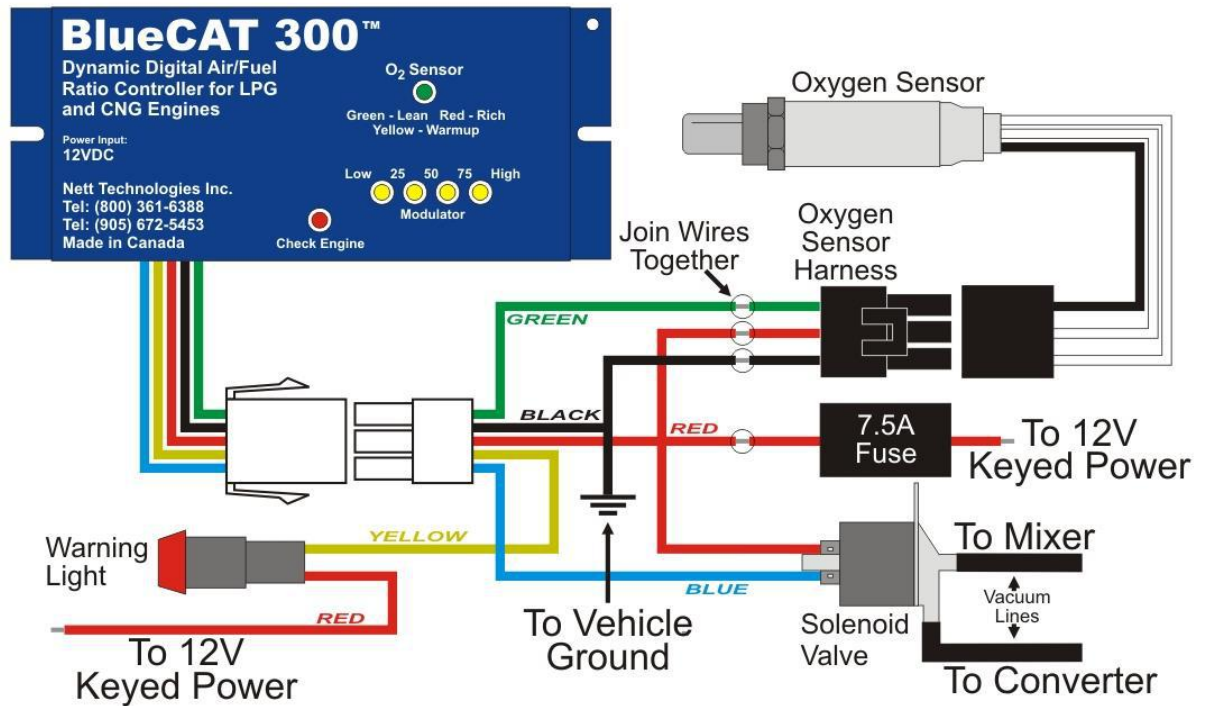

Figure 6. Electrical Connection Schematic

All electrical connections should be soldered and sealed. It is important to adequately pre-heat wires before applying solder. Cold solder joints may cause improper operation of the controller.

BlueCAT Indicator Lights

The BlueCAT electronic control unit is equipped with indicator lights, as illustrated in Figure 4. The lights allow for the initial calibration of the system, as well as for servicing and monitoring the engine operation throughout the life of the unit.



Figure 7. BlueCAT 200™ and BlueCAT 300™ share the same indicator light display.

Check Engine Light

This red color light illuminates on start-up, indicating that power is being supplied to the unit. After approximately 40 seconds the light turns off. If the controller is unable to maintain proper mixtures, the red light will come on and stay on indicating that engine maintenance and/or service is required. The failure light is triggered by rich conditions lasting longer than 1.5 - 2 minutes.

O₂ Sensor Light

This light is yellow on initial start up. After 40 seconds it becomes a monitoring light for the oxygen sensor. Green color indicates lean condition. Red color indicates rich condition. If the light is cycling steadily from green to red, it indicates proper control of the A/F mixture. The timing of A/F mixture changes should be about 1 – 2 seconds.

Steady lean condition (green) or a steady rich condition (red) indicates that the controller is unable to maintain the stoichiometric A/F ratio, signaling a problem with the engine and/or the controller system.

Modulation Lights

There are four orange lights indicating the modulation percentage of the solenoid valve. In fact, the BlueCAT pulses the solenoid between “on” and “off” many times per second. The modulation percentage is a measure of the average voltage of the pulses sent to the valve and an indication of the amount of control the solenoid is exerting over the A/F mixture. A higher modulation value indicates that the valve is “more open” and more vacuum is passed to the fuel regulator in order to lean the A/F mixture.

It is normal for these lights to oscillate indicating changing modulation, as required to control the A/F mixture. Typically, modulation oscillates around 50%, however it may change due to changing conditions, such as worn mixers, dirty air and/or fuel filters, etc. The frequency of oscillation should be about 0.5 – 1 cycle per second.

Steady modulation at either end-value indicates that the unit is unable to properly control the A/F mixture. For example, a 100% modulation indicates that the maximum amount of vacuum is being passed to the fuel regulator in an attempt to correct a rich condition. In a controllable system, this action should lean the mixture causing the modulation to decrease. However, if the system is not responding and the rich condition continues, the controller will remain in its 100% modulation state indefinitely.

Fuel System Set up Procedures

Since the controller can only lean the A/F mixture by restricting the flow of fuel in the regulator, it is necessary to adjust the vehicle's fuel system to a rich condition after the installation of the BlueCAT system. It is then the task of the controller to lean the mixture as may be required at different engine speed and load conditions or during transient operation.

The set up of the controller must be performed with the engine at proper operating temperature and at a high speed "Load" condition. This is accomplished by putting the hydraulics into bypass mode with the accelerator depressed fully. While holding the engine speed and load, adjust the power valve to attain proper oscillation between red and green on the O₂ (oxygen sensor) display light of the controller (see the calibration tip below.) At the same time, ensure that the modulation lights are at approximately 50%. If the display lights are within these guidelines the system is properly set up and no further adjustments are required.

Calibration Tip: In a properly calibrated system, the mixture oscillates between rich and lean at a frequency of about 0.5 – 1 cycle per second, as indicated by the oxygen sensor and solenoid modulation lights on the BlueCAT unit.

In practice, there are three adjustment mechanisms, addressing the A/F mixture at different speed/load conditions, as follows.

Idle operation

A/F mixture composition at idling is controlled by the *idle air bypass adjustment screw*, which is located on the body of the mixer.

Note: Some venturi systems cannot be controlled at stoichiometric during idle due to insufficient venturi vacuum at low engine speed. This is usually acceptable, as idle emissions constitute a small percentage of the total forklift truck emissions.

High load operation

A/F ratio during high load operation is controlled by the *power adjustment screw*, which is located at the fuel inlet to the mixer.

Medium speed/load conditions

The A/F ratios at intermediate load conditions are determined in air-valve mixers by the valve shape. For best results, *mixers and/or air valves designated as "feedback" should be used with A/F mixture controllers*. Consult your fuel system supplier for part numbers.

Venturi mixers do not have a medium load mixture adjustment.

Maintenance & Troubleshooting

Engine maintenance is of the utmost importance when a retrofit kit is installed. The engine must be maintained as per the engine manufacturers recommendations, otherwise the warranty will be voided. Use the engine manufacturer's manual as the basis for your engine maintenance procedures.

The following troubleshooting chart lists some possible problems related to the operation of the A/F mixture control system. Further tests may be required to diagnose catalytic converter problems using an appropriate exhaust gas analyzer.

Problem	Possible Cause	Action
Drivability problems, engine hesitation on rapid acceleration, fluctuation in engine speed.	The vacuum signal is too strong. The controller has been connected to engine manifold vacuum (i.e., vacuum from underneath the throttle).	Connect the controller to air valve or venturi vacuum (i.e., vacuum from above the throttle).
	The vacuum connection is correct, but the signal is still too strong for the vehicle's fuel system.	Vacuum elbow installed in the atmospheric vent of the propane converter has a predrilled orifice (hole) of 1.5 mm (0.060") diameter. Remove the elbow and enlarge the orifice by drilling to a 1.8 mm (0.070") diameter. Reinstall the elbow.
Rich condition. The oxygen sensor light stays red, the solenoid modulation is 100%.	Dirty intake air cleaner element.	Remove the air cleaner and run the engine. If the A/F mixture returns to normal, replace the air cleaner element.
	Vacuum leaks into converter.	Verify that vacuum hoses are properly connected. Repair or reconnect hoses, as needed.
	Vacuum hose between the solenoid and converter has been incorrectly connected to the liquid side of the converter.	(Diagnosis: the engine quits when the solenoid to converter hose is removed.) Install the vacuum hose in the atmospheric vent port on the vapor side of the converter.
	Faulty mixer, or regulator, or solenoid valve.	Create a controlled vacuum leak into the mixer. If the oxygen light starts pulsing green/red, check the mixer, regulator, and verify that the solenoid valve is working.
	Faulty oxygen sensor.	Check the oxygen sensor signal (between the green and black wires) using a voltmeter. The voltage should be cycling between 0 and 1 V. If the voltage doesn't cycle, install new oxygen sensor and re-test.
	Faulty electronic control unit.	Replace the controller.
	Dirty fuel filter.	Check and replace the fuel filter.
	Vacuum leaks into mixer.	Check vacuum hoses and connections.

Problem	Possible Cause	Action
Lean condition. Oxygen sensor light stays green for prolonged periods of time and/or during some engine conditions.	Mixer is not adjusted rich.	Create a rich condition by blocking the intake air cleaner or by injecting propane into a mixer vacuum port. If the A/F mixture returns to normal, adjust the mixer for rich mixture using its power and idle screws. If necessary, replace the standard lean valve by a feedback valve in the air valve mixer.
	Insufficient fuelling rate due to a mixer or converter/regulator problem.	Check the mixer and converter for proper operation. Fix or replace, as needed. You may also try using a lower pressure spring in the fuel regulator (e.g., replace the standard blue-coded spring with the orange spring in IMPCO mixers).
	Oxygen sensor problem	Check exhaust gas piping upstream of the sensor for air leaks, repair if necessary. Connect voltmeter to the oxygen sensor (green-black wire) and create a rich condition. If the oxygen sensor remains lean, replace it and re-test.
	Faulty electronic control unit.	Replace the controller.

Detailed Troubleshooting Procedure

Caution: Do not use a test light. Check voltages with a Digital or Analog multimeter. Make measurements with positive lead of meter, negative lead of meter to be attached to controller ground.

- 1) With key in the on position is there 12 volts to the controller? If not check the power wiring, otherwise go to step 2.
- 2) Check that the connection of the controller ground is good. Wire should be run to battery or main engine ground. If the ground is good go to step 3.
- 3) Is there 12 volts to the red wire on the fuel control valve solenoid (PN 120751)? If yes go to step 4.
- 4) If the engine starts and then quits disconnect the vacuum hose at the converter. Restart the engine. If it runs properly check the plastic vent elbow (PN 119438) and make sure that the opening is not blocked. The vent hole should be between 0.060 and 0.080 inch diameter. If this does not fix the problem go to step 5.
- 5) Check the fuel control valve solenoid (PN 120751) by blowing through the port that connects to the converter. Air should come out of the port that the filter is attached to only. Apply 12 volts to the valve; plug the filter port and blow through the valve. Air should come out of the port that goes to the mixer vacuum. If the fuel control valve checks out then go to step 6.
- 6) If the controller is showing red on the O₂ sensor light when running induce a vacuum leak. If the light turns yellow this confirms that the O₂ sensor is working.

Check to see why the engine is running rich (i.e. Plugged air filter, primary fuel pressure in the converter is too high, dirty air valve assembly in the mixer, idle or power valve set too rich). If there is still a problem with the system go to step 7.

7) If the O₂ light on the controller is yellow when running, induce more fuel and check if the light turns red. If so the O₂ sensor is working. Check to see why the engine is running lean (i.e. vacuum leak at intake manifold, PCV valve stuck open, exhaust leak before the O₂ sensor such as a blown exhaust manifold gasket, fuel tank installed incorrectly so that engine is running off vapor instead of liquid. If there is still a problem go to step 8.

8) When the engine is set up and running correctly the voltage at the blue wire on the fuel control valve will vary between 4 and 10 volts.

When the engine is set up and running correctly the voltage at the green wire from the O₂ sensor should vary between 0.1 to 0.9 volts.

Item List & Part Numbers

BlueCAT Retrofit Emissions Control System for Gaseous Fueled Engines

Items included in the BlueCAT kits are listed in the following table.

Item	Description	P/N	Qty
1	BLUECAT 200/300, DYNAMIC DIGITAL AIR/FUEL RATIO CONTROL MODULE TECHNICAL MANUAL		1
2	BLUECAT 200, DYNAMIC DIGITAL AIR/FUEL RATIO CONTROL MODULE BLUECAT 300, DYNAMIC DIGITAL AIR/FUEL RATIO CONTROL MODULE	119423	1
		119440	1
3	OXYGEN SENSOR	119424	1
4	OXYGEN SENSOR HARNESS	119425	1
5	WIRING HARNESS	119426	1
6	SOLENOID VALVE WITH BRACKET	120751	1
7	FUSE HOLDER	119428	1
8	1/2" ADEL CLAMP, 1/4" HOLE	119429	2
9	5/8" ADEL CLAMP, 1/4" HOLE	119430	1
10	CORRUGATED WRAP-AROUND SLEEVING, 1/2" OD, 3/8" ID, 6' LONG	119431	1
11	5/32" X 4' RUBBER HOSE	119432	1
12	LABEL, SERVICE FUEL SYSTEM	119433	1
13	VACUUM FITTING, BRASS	119434	1
14	SPADE CONNECTOR	119435	2
15	7.5amp FUSE	119436	1
16	RING CONNECTOR	119437	1
17	VACUUM ELBOW, PLASTIC	119438	1
18	WARNING LIGHT	119439	1

YOUR PRODUCT WARRANTY RIGHTS AND OBLIGATIONS

Nett Technologies Inc. warrants the LSI retrofit emission control system to be free from defects in design, materials, workmanship, or operation of the LSI retrofit emission control system which cause the LSI retrofit emission control system to fail to conform to the emission control performance level it was verified to, or to the requirements in the California Code of Regulations, Title 13, Chapter 9, Article 8, Sections 2780 to 2786, and 2789, for 3 years or 2,500 hours, whichever occurs first, pursuant to Section 2787(a)(1), provided there has been no abuse, neglect, or improper maintenance of the LSI retrofit emission control system, engine or equipment, as specified in the owner's manuals. Where a warrantable condition exists, this warranty also covers the engine from damage caused by the LSI retrofit emission control system, subject to the same exclusions for abuse, neglect or improper maintenance. Please review your owner's manual for other warranty information. Your LSI retrofit emission control system may include a core part (e.g. three-way catalyst, carburetor, mixer or regulator) as well as hoses, connectors, and other emission-related assemblies. Where a warrantable condition exists, Nett Technologies Inc. will repair or replace your LSI retrofit emission control system at no cost to you including diagnosis, parts, and labor.

WARRANTY COVERAGE

For a 1.4L to 6.0L Large Spark Ignition engine used in a Non-Road application, the warranty period will be 3 years or 2,500 hours of operation, whichever occurs first. If any emission-related part of your LSI retrofit emission control system is defective in design, materials, workmanship, or operation of the LSI retrofit emission control system thus causing the LSI retrofit emission control system to fail to conform to the emission control performance level it was verified to, or to the requirements in the California Code of Regulations, Title 13, Chapter 9, Article 8, Sections 2780 to 2786, and 2789, within the warranty period, as defined above, Nett Technologies Inc. will repair or replace the LSI retrofit emission control system, including parts and labor.

In addition, Nett Technologies Inc. will replace or repair the engine components to the condition they were in prior to the failure, including parts and labor, for damage to the engine proximately caused by the verified LSI retrofit emission control system. This also includes those relevant diagnostic expenses in the case in which a warranty claim is valid. Nett Technologies Inc. may, at its option, instead pay the fair market value of the engine prior to the time the failure occurs.

OWNER'S WARRANTY RESPONSIBILITY

As the (engine, equipment) owner, you are responsible for performing the required maintenance described in your owner's manual. Nett Technologies Inc. recommends that you retain all maintenance records and receipts for maintenance expenses for your engine or equipment, and LSI retrofit emission control system. If you do not keep your receipts or fail to perform all scheduled maintenance, Nett Technologies Inc. may have grounds to deny warranty coverage. You are responsible for presenting your equipment or engine, and LSI retrofit emission control system to Nett Technologies Inc. or a Nett Technologies Inc. dealer as soon as a problem is detected. The warranty repair or replacement should be completed in a reasonable amount of time, not to exceed 30 days. If a replacement is needed, this may be extended to 90 days should a replacement not be available, but must be performed as soon as a replacement becomes available.

If you have questions regarding your warranty rights and responsibilities, you should contact Wayne Moffat at 1-800-361-6388 Extension 124 or via email at



wmoffat@nettinc.com or the California Air Resources Board at 9528 Telstar Avenue, El Monte, CA 91731, or (800) 363-7664, or electronic mail: helpline@arb.ca.gov.

Installation Warranty

The installer shall provide a written warranty with each new LSI retrofit emission control system installed for an owner. The installer shall deliver the written warranty to the owner at the time of installation. The warranty must contain the following:

YOUR INSTALLATION WARRANTY RIGHTS AND OBLIGATIONS

The Installer must warrant that the installation of an LSI retrofit emission control system is free from defects in workmanship or materials which cause the LSI retrofit emission control system to fail to conform to the emission control performance level it was verified to, or to the requirements in the California Code of Regulations, Title 13, Sections 2781 to 2786 and 2789.

OWNER'S WARRANTY RESPONSIBILITY

As the engine or equipment owner, you are responsible for presenting your engine or equipment and LSI retrofit emission control system to the installer as soon as a problem with the installation is detected.

If you have questions regarding your warranty rights and responsibilities, you should contact the installer or the California Air Resources Board at 9528 Telstar Avenue, El Monte, CA 91731, or (800) 363-7664, or electronic mail: helpline@arb.ca.gov.