

Diesel engine emission control has never been easier!

Diesel generators are an excellent power source, with the exception of their emissions. Particulate Matter (PM)/soot is a significant contributor to air pollution causing negative environmental and health effects worldwide.

Nett Technologies' GreenTRAP™ 100d is a passive Diesel Particulate Filter (DPF) system that is designed to control PM emissions from diesel engines in off-road applications. It's equipped with an upstream Diesel Oxidation Catalyst (DOC) to simultaneously oxidize Carbon Monoxide (CO), Hydrocarbons (HC) and aldehydes contained in diesel exhaust into non-toxic compounds: carbon dioxide and water vapor. The GreenTRAP™ 100d system utilizes cordierite wall-flow monoliths to trap the soot produced by diesel engines. A proprietary catalyst is coated onto the inner surface of the filter monolith which lowers the soot combustion temperature allowing the filter to self-clean (regenerate) at lower exhaust temperatures. All of the accumulated soot inside the filter can be oxidized during regular operation of the engine. Under favorable engine operating conditions, the system has a 95-99% PM reduction. In addition, the GreenTRAP™ 100d will reduce CO and HC emissions by more than 98% and 82% respectively.

Nett Technologies' GreenTRAP™ 100d DPF+DOC system is an excellent way to control and remove harmful diesel emissions. Contact your representative today to receive more information about the emission control solutions for your off-road diesel engines.

GreenTRAP™

100d

passive diesel particulate filter with diesel oxidation catalyst

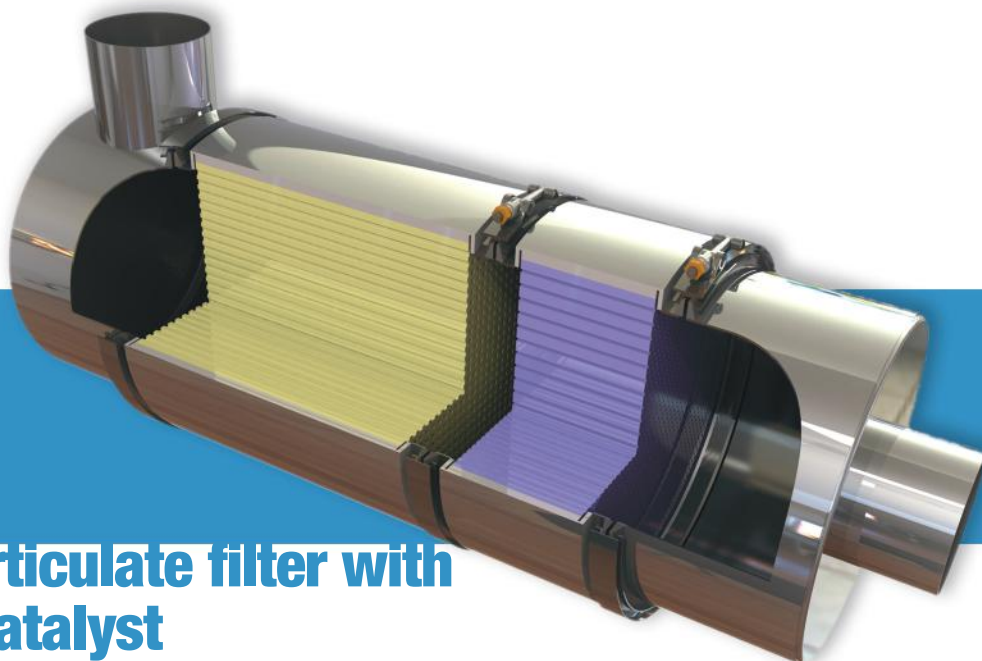

scan and learn



Sold and supported globally, Nett Technologies Inc., develops and manufactures proprietary catalytic solutions that use the latest in diesel oxidation catalyst (DOC), diesel particulate filter (DPF), selective catalytic reduction (SCR), engine electronics, stationary engine silencer, exhaust system and exhaust gas dilution technologies. Our reliable and real-world emission solutions will extend the usable life of existing equipment while allowing you to avoid costly future replacements. We manufacture emission control solutions that are California Air Resources Board (ARB) and the U.S. Environmental Protection Agency (EPA) verified. As the emission control authority, we are here to help you navigate through the hassles and complexities of emission control compliance.

NETT
TECHNOLOGIES INC.
...the emission control authority.

www.nettinc.com

GreenTRAP™ 100d PRODUCT OVERVIEW

How does the GreenTRAP™ 100d system work?

Nett Technologies' GreenTRAP™ 100d system includes a passive Diesel Particulate Filter (DPF) system equipped with an upstream Diesel Oxidation Catalyst (DOC). The system and its main components are depicted below. The GreenTRAP™ 100d utilizes a cordierite wall-flow monolith to trap the soot produced by diesel engines. The cylindrical filter element consists of many parallel channels running in the axial direction, separated by thin porous walls. The channels are open at one end and plugged at the other, forcing the particle laden exhaust gases to flow through the walls. Gases are able to escape through the pores in the wall material, but particulates are too large to escape and are trapped inside the filter.

A proprietary catalyst is coated onto the inner surface of the filter monolith. The catalyst lowers the soot combustion temperature allowing the filter to regenerate at lower exhaust temperatures. The accumulated soot inside the filter can be oxidized during regular operation of the engine. Exhaust temperatures of 250-300 °C (482-572 °F) for 25-30% of the operation time are necessary for proper filter regeneration when Ultra-low Sulfur Diesel (ULSD) fuel is used. Nett Technologies' filters can also be used with other fuels and with diesel with up to 50ppm sulfur content; however, higher exhaust temperatures will be required for regeneration which can be achieved on most medium and heavy-duty diesel engine applications.

The GreenTRAP™ 100d utilizes a precious metal coated DOC upstream of the DPF unit. The DOC core is made of corrugated, high temperature resistant stainless steel foil, packaged into rugged stainless steel containers. The DOC oxidizes Carbon Monoxide (CO), Hydrocarbons (HC) and aldehydes contained in diesel exhaust to non-toxic compounds: carbon dioxide and water vapor. Under favorable engine operating conditions, the system can reduce up to 98% of CO, 82% HC and 98% of PM. The PLOG™ 270DPF monitoring system (optional) along with 2 temperature sensors and 1 differential pressure sensor are used to monitor and log data from the DPF backpressure and DOC/DPF inlet/outlet temperature sensors in real-time. The monitoring system will notify the operator of possible system issues and will help ensure problem-free operation for the life span of the system.

GreenTRAP™ 100d System Schematic Drawing

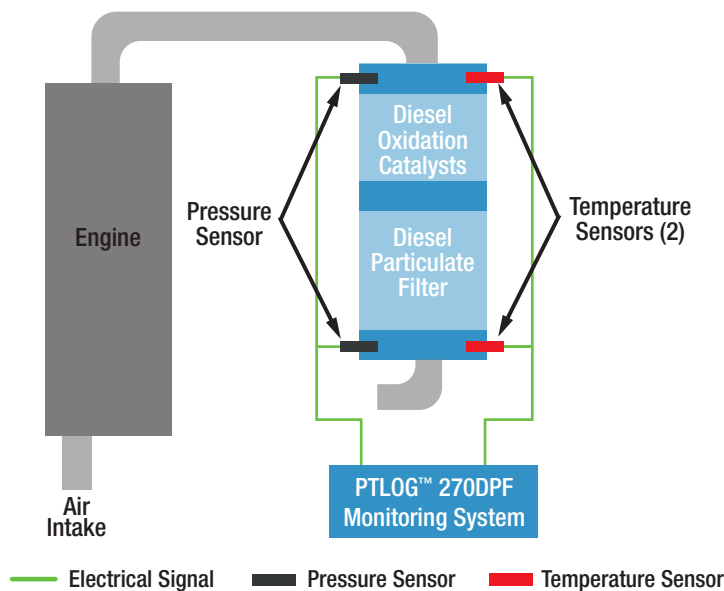

PRODUCT FEATURES

- Passive regeneration system (self-cleaning)
- Ideal for diesel engines used in off-road applications (construction, mining, material handling)
- Compact design with thermal insulation (optional)
- Computerized controller with 3 customizable alarms and data logging capabilities (optional)
- System maintenance intervals of 2000 to 6000 hours
- Stainless steel housing, custom-fit designs available
- Bypass valve (optional)

EMISSIONS REDUCTION PERFORMANCE

Typical GreenTRAP™ 100d Emissions Reduction Performance

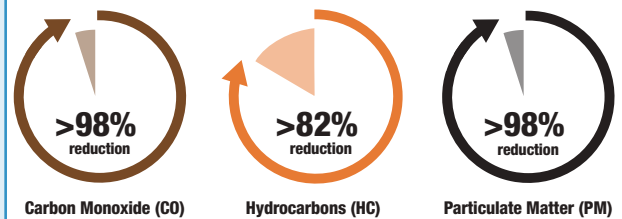

...the emission control authority.

Contact Nett Technologies Inc. today at:

Phone: (905) 672-5453 Toll-Free: 1(800) 361-6388
or visit us online at www.nettinc.com

Distributed by:

