

Diesel generator emission control has never been easier!

Diesel generators are an excellent power source, with the exception of their emissions. Particulate Matter (PM)/soot and Oxides of Nitrogen (NO_x) are significant contributors to air pollution causing negative environmental and health impacts worldwide.

The BlueMAX™ VOLT 300 is an emission control system consisting of a Diesel Particulate Filter (DPF) upstream of a Selective Catalytic Reduction (SCR). It is designed to control emissions of both PM and NO_x from medium and heavy duty diesel engines in stationary applications. The system uses a proprietary catalyst on the inner surfaces of the DPF walls which reduces the regeneration temperature and therefore allows the system to passively regenerate in favorable engine exhaust operating temperatures. When temperature is not sufficient for passive regeneration, a set of electric heater coils are used to increase the exhaust temperature for active regeneration. An Electronic Control Unit (ECU) evaluates the system parameters such as temperature, pressure and exhaust mass flow rate in real time and uses these values to predict and activate the regeneration cycle.

In the Nett BlueMAX™ VOLT 300, NO_x is reduced over the SCR catalyst through chemical reaction with Diesel Exhaust Fluid (DEF). The SCR sub-system consists of the SCR catalytic converter, a DEF dosing unit, and the DEF tank (see diagram). The DEF control strategy relies on NO_x concentration measurements by a sensor positioned upstream of the SCR catalyst. Based on the NO_x sensor signal in combination with an engine mass air flow sensor and temperature sensors, the ECU calculates the amount of urea which needs to be injected for optimum NO_x reductions. The NO_x sensor-based control strategy makes the system very suitable for both original equipment and retrofit applications. System calibration (i.e. engine mapping) is not required and the system can be installed on a wide range of diesel engines, both mechanically and electronically controlled.

The Nett BlueMAX™ VOLT 300 ECU continuously monitors and measures the performance of all system sensors and components. In the event of malfunction, the ECU will indicate the existence of a problem to the operator via the system display. Under favorable operating conditions, the system can achieve up to 99% reduction in NO_x, up to 98% reduction in PM, up to 94% reduction in hydrocarbons (HC), and up to 96% reduction in carbon monoxide (CO). It can also reduce volatile organic compounds (VOCs) and hazardous air pollutants (HAPs) by up to 95%. These values represent the system's achievable efficiency under optimized conditions and highlight the full potential of advanced emission control technology for cleaner, more sustainable operation.

BlueMAX™ VOLT 300 SCR + Active DPF system



scan and learn



Sold and supported globally, Nett Technologies Inc., develops and manufactures proprietary catalytic solutions that use the latest in diesel oxidation catalyst (DOC), diesel particulate filter (DPF), selective catalytic reduction (SCR), engine electronics, stationary engine silencer, exhaust system and exhaust gas dilution technologies. Our reliable and real-world emission solutions will extend the usable life of existing equipment while allowing you to avoid costly future replacements. We manufacture emission control solutions that are California Air Resources Board (ARB) and the U.S. Environmental Protection Agency (EPA) verified. As the emission control authority, we are here to help you navigate through the hassles and complexities of emission control compliance.

NETT
TECHNOLOGIES INC.
...the emission control authority.

www.nettinc.com

BlueMAX™ VOLT 300 PRODUCT OVERVIEW

How does the BlueMAX™ VOLT 300 System work?

Nett Technologies' BlueMAX™ VOLT 300 is a Passive/Active DPF and SCR system which is designed to control emissions of Particulate Matter (PM) and Oxides of Nitrogen (NO_x) from medium and heavy-duty diesel engines in stationary applications. The system contains a set of electric heater coils that are used to increase the temperature of the exhaust for active regeneration allowing the system to run without relying on engine exhaust temperatures.

The wall-flow DPF traps PM/soot emissions emitted by the diesel engines. The cylindrical filter element of the device consists of many square parallel channels running in axial direction, separated by thin porous walls. A proprietary catalyst is wash-coated on the inner surfaces of the monolith channels. The inner catalyst lowers the PM oxidation temperature allowing filter to passively regenerate at lower temperatures.

When the exhaust temperature is not sufficient for passive regeneration, an active regeneration will be automatically triggered. During active regeneration, the electrical control unit utilizes excessive power of your generator in a controlled manner to increase the exhaust temperature to levels that can safely oxidize collected soot in the DPF.

NO_x is reduced over the SCR catalyst through chemical reaction with a reducing agent 'urea' commonly referred to as Diesel Exhaust Fluid (DEF). The urea control strategy relies on NO_x concentration measurements by a sensor positioned upstream of the SCR catalyst. Based on the NO_x sensor signal, in combination with an engine mass air flow sensor and temperature sensors, the ECU calculates the amount of urea which needs to be injected for optimum NO_x reductions.

BlueMAX™ VOLT 300 System Schematic Drawing

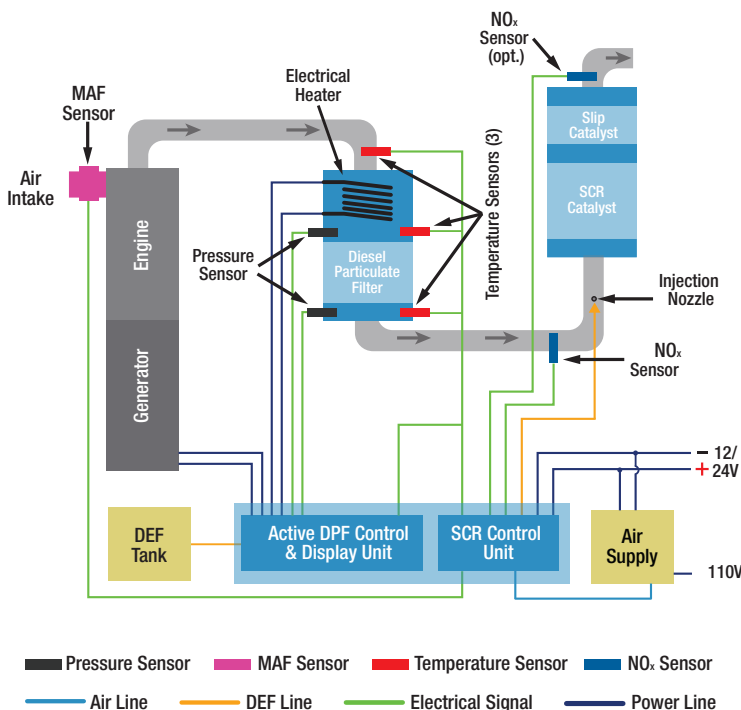

PRODUCT FEATURES

- Active DPF (electrically regenerated) and urea-SCR system
- Internally and externally (optional) insulated
- Computerized controller with 3 customizable alarms
- Maintenance intervals of 2000 to 6000 hours
- Programmable regeneration profile with data logging capabilities
- Colour display informing of system operational conditions and status
- Continuous generator load monitoring for optimum regeneration strategy
- Energy efficient with quiet operation

EMISSIONS REDUCTION PERFORMANCE

Typical BlueMAX™ VOLT 300 Emissions Reduction Performance



Carbon Monoxide (CO)

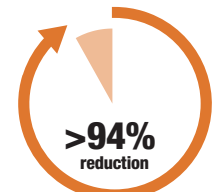

Hydrocarbons (HC)

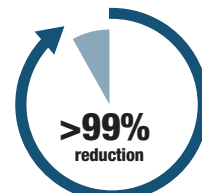

Nitrogen Oxides (NO_x)



Particulate Matter (PM)



...the emission control authority.

Contact Nett Technologies Inc. today at:

Phone: (905) 672-5453 Toll-Free: 1(800) 361-6388

or visit us online at www.nettinc.com

Distributed by: