

# Diesel generator emission control has never been easier!

Diesel generators are a reliable and efficient power source; however, particulate matter (PM/soot) and exhaust emissions remain a significant contributor to environmental and health concerns.

The GreenTRAP™ 300d is an advanced passive Diesel Particulate Filter (DPF) system designed for stationary diesel engine applications. The system integrates a Diesel Oxidation Catalyst (DOC) upstream of a wall-flow DPF to deliver reliable and high-efficiency emissions control.

The DOC oxidizes carbon monoxide (CO), hydrocarbons (HC), and aldehydes into carbon dioxide (CO<sub>2</sub>) and water vapor (H<sub>2</sub>O), while the cordierite wall-flow DPF captures particulate matter (soot) within its porous structure. A proprietary catalyst coating on the filter walls lowers soot oxidation temperature, enabling passive regeneration during normal engine operation without the need for active intervention.

Under favorable operating conditions, accumulated soot is continuously oxidized within the filter, ensuring stable performance and reduced maintenance requirements.

The system delivers up to 99% reduction in particulate matter (PM), up to 99% reduction in carbon monoxide (CO), and up to 96% reduction in hydrocarbons (HC), including associated volatile organic compounds (VOCs) and hazardous air pollutants (HAPs)\*.

Customized to fit specific applications, the GreenTRAP™ 300d provides full control over emissions while improving engine performance, reducing operational impact, and extending equipment life.

## GreenTRAP™ 300d Passive Diesel Particulate Filter

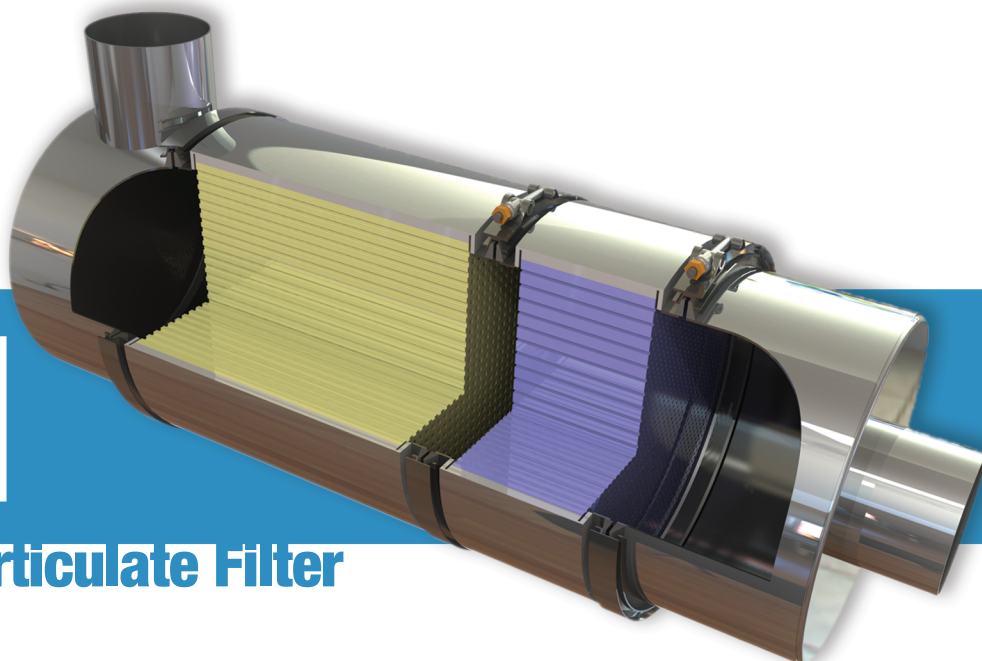

scan and learn



Sold and supported globally, Nett Technologies Inc., develops and manufactures proprietary catalytic solutions that use the latest in diesel oxidation catalyst (DOC), diesel particulate filter (DPF), selective catalytic reduction (SCR), engine electronics, stationary engine silencer, exhaust system and exhaust gas dilution technologies. Our reliable and real-world emission solutions will extend the usable life of existing equipment while allowing you to avoid costly future replacements. We manufacture emission control solutions that are California Air Resources Board (ARB) and the U.S. Environmental Protection Agency (EPA) verified. As the emission control authority, we are here to help you navigate through the hassles and complexities of emission control compliance.

**NETT**  
TECHNOLOGIES INC.  
...the emission control authority.

[www.nettinc.com](http://www.nettinc.com)

## GreenTRAP™ 300d PRODUCT OVERVIEW

### How does the GreenTRAP™ 300d system work?

Exhaust gases first pass through the Diesel Oxidation Catalyst (DOC), where carbon monoxide (CO), hydrocarbons (HC), and aldehydes are oxidized into carbon dioxide (CO<sub>2</sub>) and water vapor (H<sub>2</sub>O).

The gases then flow into the wall-flow Diesel Particulate Filter (DPF), where particulate matter (soot) is captured within the porous channel walls. The filter consists of parallel channels that force exhaust gases through the walls, trapping particles while allowing clean gases to pass through.

A proprietary catalyst coating on the filter lowers the soot oxidation temperature, enabling passive regeneration during regular engine operation.

For effective regeneration, exhaust temperatures of approximately 250-300°C (482-572°F) must be maintained for about 25-30% of operating time, particularly when using ultra-low sulfur diesel (ULSD) fuel.

The system is compatible with multiple fuel types; however, fuels with sulfur content above 50 ppm require higher exhaust temperatures for proper regeneration.

The DOC core is constructed from corrugated, high-temperature resistant stainless steel foil with a precious metal catalyst, housed within a durable stainless steel enclosure.

A monitoring system, including two temperature sensors and one differential pressure sensor, enables real-time tracking of DPF backpressure and DOC/DPF inlet and outlet temperatures, ensuring reliable system operation and early fault detection.

### GreenTRAP™ 300d System Schematic Drawing

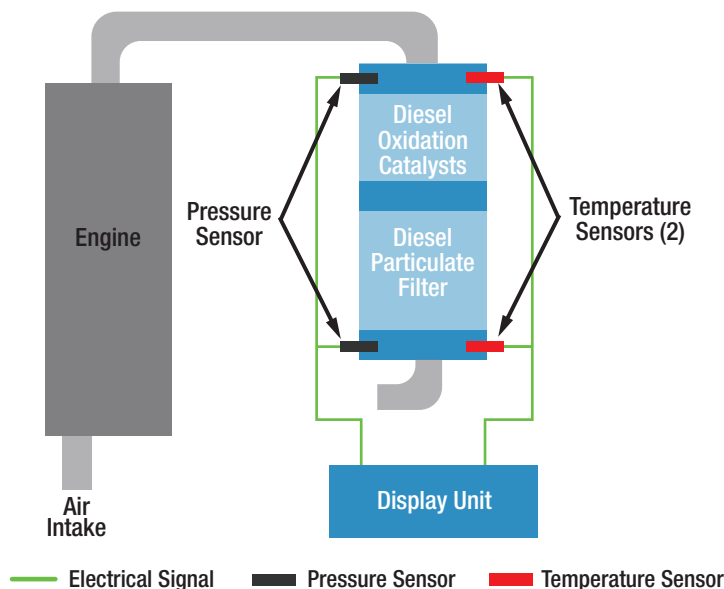

## PRODUCT FEATURES

- Passive DOC + DPF system (no active regeneration required)
- Designed for stationary diesel engine applications (power generation, gas compression, co-generation, pumping, irrigation)
- Cordierite wall-flow filter technology
- Precious metal catalyst-coated DOC core
- Compact, thermally insulated design
- Optional computerized controller with alarms and data logging
- Real-time monitoring with temperature and pressure sensors
- Maintenance intervals of 2000 - 6000 hours
- Stainless steel housing with custom-fit configurations available
- Optional bypass valve for operational flexibility

## EMISSIONS REDUCTION PERFORMANCE

### Typical GreenTRAP™ 300d Emissions Reduction Performance\*

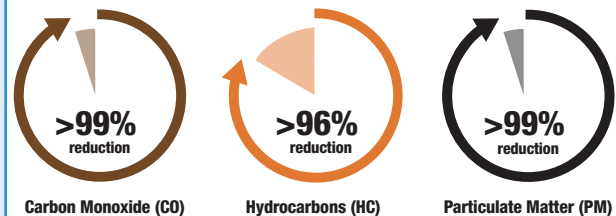

\*Actual emission reduction performance depends on catalyst formulation, engine calibration, exhaust temperature, and operating conditions. With optimized system design and proper application, catalyst technologies are capable of achieving enhanced conversion efficiencies in



...the emission control authority.

Contact Nett Technologies Inc. today at:

Phone: (905) 672-5453 Toll-Free: 1(800) 361-6388

or visit us online at [www.nettinc.com](http://www.nettinc.com)

Distributed by:



15-0033